

Key Words: 3D Printing, Dimensional Printing, Measurement, Gage, Gage R & R, Metrology

Paper Title: Metrology for 3D Printing: Assessing Methods for the Evaluation of 3D Printing Products

According to Blum & Smithers-PIRA (2105), the collective industry which professional three-dimensional (3D) printing and printed electronics is projected to be \$67.4 billion in 2015, double from the 2010 value, and this it is expected to grow to nearly \$108 billion by 2020. As 3D printing technologies are frequently used to manufacture interchangeable parts and for applications such as rapid prototyping, it is little surprise that a growing body of research has examined the accuracy of these devices (e.g. Ostrout, 2015). It is customary for these studies to utilize digital microscopes together with appropriate imaging software to analyze and quantify the unique nature of 3D printed samples. It is recognized that such microscopes are generally rather costly, and are not especially intuitive to use. An alternative to digital microscopes would therefore be welcome, such a solution would need to be capable of measuring not only length and width (x and y directions), but also in height (z direction).

One measurement technology that could be utilized for measurement of 3D printed products is the Flexographic plate meter. Although these meters are designed to measure flexographic relief plates, there is a possibility that they could be utilized to measure 3D printed products, as well.

The present study examines and compares digital microscope technology with a commercial available flexographic plate meter. Specifically, a Keyence VHX-2000E digital microscope (VHX) is compared to a BetaFlex Pro plate meter in 3D printing applications by reading the same 3D printed samples and examining the subsequent data using descriptive statistics and a Gage Repeatability and Reproducibility (R&R) study.

Specifically, specially designed test target consisting of a non-intersecting straight line printed using both a Fused-Layer Modeling (FLM)¹ printer and Stereolithographic (SLA) printer is utilized. The resulting test target is analyzed in the z-direction using commonly accepted Gage R&R procedures.

The goal of the Gage R&R is to quantify measurement uncertainty due to the combination of the variance in instrumentation and in users. The study identifies the total variation interval from the repeatability uncertainty interval due to instrument variation, and the reproducibility uncertainty interval representing the inability of different users of the same gage to produce the same result when measuring an identical sample versus the variation due to the printed samples alone as a means to compare the two measurement methods.

¹ Many use the term Fused Deposition Modeling (FDM) to describe the more generic Fused Layer Modeling (FLM). As FDM is a registered trade name for a fused layer process offered by Stratsys Company, the generic FLM term is utilized here (Gebhardt, 2012).

The study concludes with implications and recommendations for metrics to quantify the uncertainty of 3D printing devices.

Materials:

SolidWorks software for development of the sample

Microsoft Excel for data analysis

FLM 3D Printer

SLA 3D Printer

Digital Microscope and Analysis Software: Keyence VHX-2000E

Flexographic Plate Meter and Analysis Software: BetaFlex Pro

It is important to recognize that the digital microscope is designed to be utilized in a wide range of applications, where the BetaFlex Pro is designed specifically to measure flexographic printing plates; this instrument features adjustments for illuminant and range and is corrected for the oblique angle of the camera. According to the U.S. distributor it has a limited depth of focus, and can measure samples up to 0.025" (0.635 mm) in the z-direction.

Methods:

Using SolidWorks software, a 3D printed sample was designed to produce a base with a line feature at a specified height, as follows:

0.024" (0.6 mm)

0.020" (0.5mm)

0.16" (0.4mm)

An illustration of the feature is shown in Figure 1.

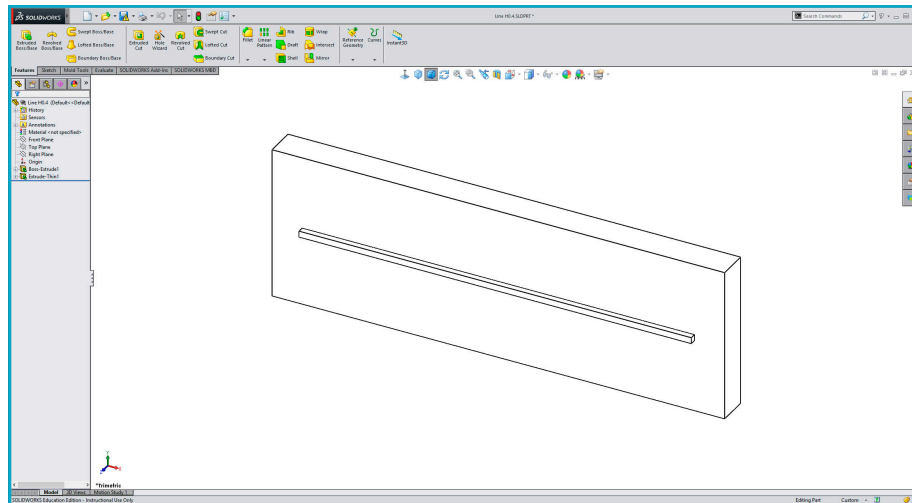

Figure 1. Illustration of 3D Printed Sample Used in SolidWorks Software

These three files were output using two different 3D printing methods, namely fused-layer modeling (FLM) and stereolithography (SLA).

Fused-Layer Modeling (FLM):

According to Gebhardt (2012), FLM is the “...layer-by-layer deposition of pasty strings...The process works with prefabricated thermoplastic material.” (p. 45). An FLM printer is comprised of a heated chamber outfitted with an extrusion head and a descending/elevating platform on which the product is built. The head extrudes thermoplastic material in the x,y area in a process similar to that of a plotter, while the platform moves in the z-direction and dictates the thickness of the layer by lowering the amount of one layer thickness, and then the next layer is extruded. (Gebhardt, 2012)

Stereolithography (SLA)

SLA, manufactured by 3D Systems, is regarded as a process which is capable of producing detailed samples with good surface qualities. Similar to FLM technology, SLA printers feature a chamber with a descending/elevating platform, but in this case samples are created by the local polymerization of an initially liquid polymeric emulsion by an Ultra-Violet (UV) laser. The initial layer is created with the platform slightly below the surface of the polymeric emulsion, and the layer is drawn onto the surface with light from the UV laser, which turns the liquid into a solid through polymerization, leaving a scaled solid layer. When the first layer is completed, the platform descends the distance of one layer and the second layer is created through the same process, with the process repeating for each subsequent layer (Hoskins, 2013).

Measurement:

Once produced, the three samples are then subsequently evaluated quantitatively and qualitatively by both the VHX digital microscope and the BetaFlex Pro using the respective software for measuring the z-direction of the feature. Three trained operators measured each sample three times, samples were presented to the operators in random order consistent with recommendations of the Automotive Industry Action Group (2010). Data are collected and analyzed using standard procedures for Gage R&R.

Initial Observations:

Upon inspection under magnification, it was immediately noted that the FLM technology resulted in a poorly rendered line edge which made it impossible to read effectively with the BetaFlex Pro, and this resulted in an important realization about the limitations of using this particular device in the present application. With the BetaFlex Pro software, the user is required to set the top of the feature and drag to the bottom of the feature to measure the height; although this process is similar to that of the digital microscope a limitation was realized. As the BetaFlex Pro is designed to measure halftone dots on flexographic relief plates and not lines, the only place to measure the samples using this device was at the ends of the line. As shown in Figure 2, the line ends manufactured with the FLM technology were bulbous in shape when compared to the middle of the line; therefore, there was no effective way to set the top of the feature consistently. The digital microscope, with the ability to set the top of the feature at any position along the line did not share that limitation of only being able to read at the line ends. Based on this realization, the present research does not support using the BetaFlex Pro for the measurement of FLM samples.

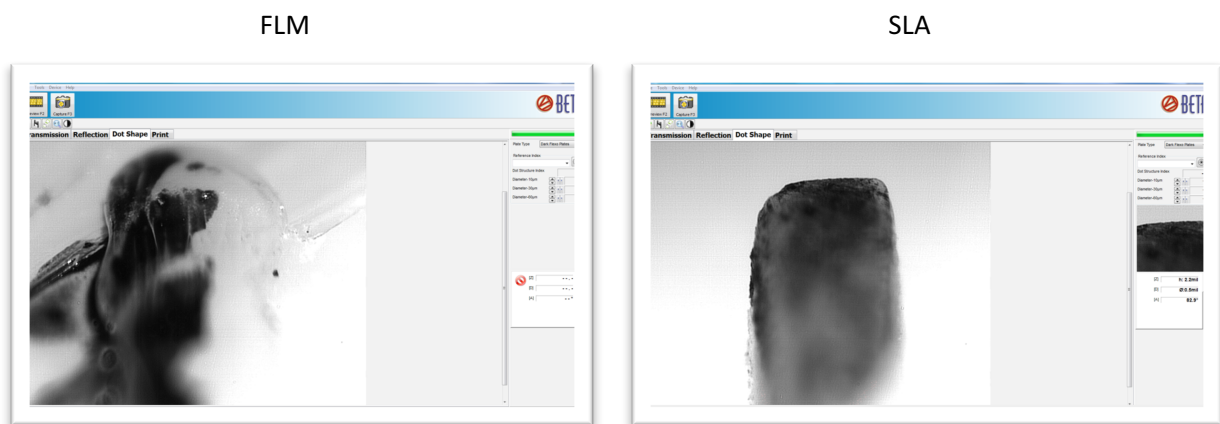

Figure 2. BetaFlex Pro Images showing FLM Feature versus SLA Feature

In a visual evaluation of the samples produced with SLA, a more clearly defined line edge results. This well-defined edge is not only in the middle of the line, but also at the ends and can therefore be more realistically measured by the BetaFlex Pro. In this instance, therefore, the analysis between the measurement technologies was conducted on SLA samples only.

Using the SLA printed samples, three different operators measured each sample a total of three times using each measurement instrument.

Results:

A summary of the central tendency and range are provided in Table 1. Consistently, the measured values of the z-direction were less than the heights specified in the digital file, regardless of whether the VHX digital microscope or the BetaFlex Pro were utilized. In general, the BetaFlex Pro measured the z-direction lower than the VHX digital microscope. Further, using the flexographic meter resulted a greater variance in measurement when compared to the digital microscope.

0.016" Feature		Min	Max	Range	Mean
	VHX	11.33	12.4	1.06	11.87
	Beta Flex	8.2	10.6	2.4	9.54
0.020" Feature					
	VHX	14.16	15.73	1.58	15.01
	Beta Flex	13.5	15.9	2.4	14.53
0.024" Feature					
	VHX	2.54	21.36	0.82	20.91
	Beta Flex	16.6	18.4	1.8	17.3

Table 1. Descriptive Statistics: Central Tendency and Range

These observations are reinforced by a subsequent ANOVA-based Gage R&R analysis. The ANOVA results are provided in Tables 2 and 3, with a graphical analysis shown in Figures 3 and 4. In addition, the variance components displayed in Tables 4 and 5.

Source	<i>df</i>	<i>ss</i>	<i>ms</i>	<i>F</i>	<i>p</i>
Part	2	379.029	189.514	3423.26	< 0.001
Operator	2	0.691	0.345	6.24	0.059
Part*Operator	4	0.221	0.055	0.31	0.869
Repeatability	18	3.245	0.180		
Total	26	383.187			

Table 2: Gage R&R ANOVA for VHX Digital Microscope

Sources	<i>df</i>	<i>ss</i>	<i>ms</i>	<i>F</i>	<i>p</i>
Part	2	278.076	139.038	82.907	0.001
Operator	2	3.567	1.784	1.0636	0.426
Part*Operator	4	6.708	1.677	6.7281	0.002
Repeatability	18	4.487	0.249		
Total	26	292.839			

Table 3: Gage R&R ANOVA for BetaFlex Pro

The graphical analysis in Figures 3 and 4 support the differences noted in the descriptive means and range, especially as shown in the Part by Operator Interaction graph illustrated in the lower right of Figures 3 and 4, which clearly show the variation among operators is greater with the BetaFlex Pro when compared to the VHX digital microscope.

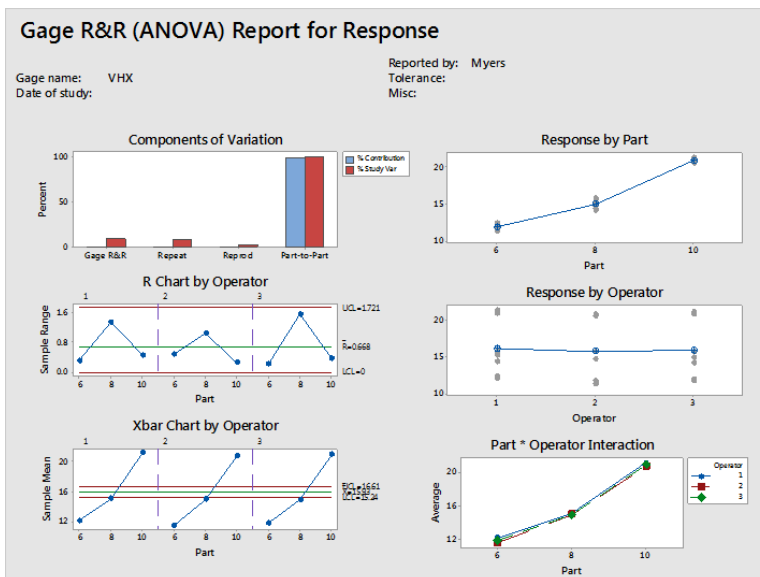

Figure 3: VHX Digital Microscope Gage R&R Report for Response

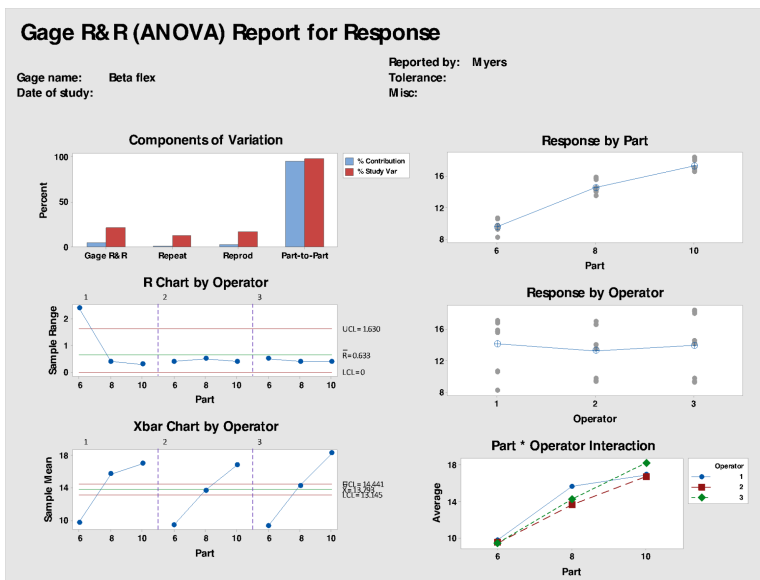

Figure 4: BetaFlex Pro Gage R&R Report for Response

In examining the variance components, particularly the variation due to the difference in the samples (part to part variation), the study turns to tables 4 and 5, where the data indicate that with the BetaFlex Pro 95.39% of the contribution to the total variation is due to the samples, where with the VHX this number increases to over 99%. This supports that initial observation in the descriptive statistics that there is less variation due to the user and measurement instrument when the digital microscope is utilized.

Source	VarComp	% Contribution (of VarComp)
Total Gage R&R	0.1785	0.84
Repeatability	0.1576	0.74
Reproducibility	0.0209	0.10
Operator	0.0209	0.10
Operator*Part	0.4759	2.97
Part-to-Part	21.0397	99.16
Total Variation	21.2181	100
Number of Distinct Categories = 6		

Table 4: VHX Digital Microscope Pro Variance Components

Source	VarComp	% Contribution (of VarComp)
Total Gage R&R	0.7370	4.61
Repeatability	0.2493	1.56
Reproducibility	0.4878	3.05
Operator	0.0119	0.07
Operator*Part	0.4759	2.97
Part-to-Part	15.2623	95.39
Total Variation	15.9994	100
Number of Distinct Categories = 6		

Table 5: BetaFlex Pro Variance Components

Conclusions and Implications:

In conclusion, as a device to measure 3D printed samples the BetaFlex Pro is limited in accuracy when compared to the digital microscope. Although users reported it to be easier to use and faster than the digital microscope, the software offers fewer controls. It is noted that if the BetaFlex Pro were to be

used to measure FLM samples it should be relegated to reading in the length and width (x and y) directions only.

The flexographic plate meter does however, offer promise for some applications beyond its intended purpose of measuring flexographic relief plates. For example, it offers a rather impressive array of controls to handle the wide variety of relief plates on the market, which makes the device rather adaptable; just not as adaptable as a digital microscope. Furthermore, it would not be difficult to remove the reading head from the provided base and construct a rig to make it simplify sample placement and optimize the device to measure different types of samples from a variety of sources. The BetaFlex Pro reading head only need be used in the provided mounting arm when transmission readings are taken. Overall, however, it is unlikely that a 3D printing operation would purchase a BetaFlex Pro for measurement of 3D printed samples, if an organization already had one on hand the present analysis concludes that it could be useful for measuring line widths and lengths, and the z-direction of 3D printed samples from technologies that produce clearly defined edges.

Acknowledgements:

The researchers would like to thank Larry Goldberg and Beta Screen for their support with the BetaFlex Pro as well as Sandeep Yanelli and Li Heng, Rochester Institute of Technology School of Media Sciences Graduate Students for their assistance.

Bibliography:

Automotive Industry Action Group (AIAG), *Preparation for a Measurement System Study MSA*, fourth edition, Section C, 2010.

Blum, H., & Smithers Pira. (2015). *The future of 3D printing to 2025*. Portland, Maine,; Surrey England: Smithers Pira.

Gebhardt, A. (2012). *Understanding Additive Manufacturing*. Munich, Germany: Hanser.

Hoskins, S. (2013). *3D Printing for Artists, Designers and Makers*. London, England: Bloomsbury.

Ostrout, N. (2015). *Quantifying a fused deposition modeling system's dimensional performance through its addressability*. (Order No. 1589637). Available from ProQuest Dissertations & Theses Global. (1688687515). Retrieved from <http://search.proquest.com>.

Metrology for 3D Printing: Assessing Methods for the Evaluation of 3D Printing Products

Bruce Leigh Myers, Ph.D.
with
Shu Chang, Ph.D.



68th Annual Technical Conference - Memphis, TN 2016

Research Inspiration

- Three Dimensional (3D) Printing has experienced explosive growth in recent years
 - Billed as "The Next Revolution in Manufacturing"
 - Declared "World-Changing Technology" by the Economist and Wired*
 - Collective Industry of including professional 3D printing and printed electronics \$67.4 billion in 2015, double from 2010 value. Projected to grow to nearly \$108 billion by 2020**

*Source: New York Times 2014
**Source: Smithers-PIRA 2016

Memphis, TN 2016

68th Annual Technical Conference
taga@c.printing.org



3D Printing and Commercial Printers*

- A Mature Market
 - Large number of Service Bureaus
- For Commercial Printers, Early Adoption Phase Largely Over
- Most No Longer Proactively Marketing
- Adoption Growing at Larger Chains
 - Entry-level, Limited Substrates

*Source: Tolliver-Walker, *Printing News*, October, 2015

Memphis, TN 2016

68th Annual Technical Conference
taga@c.printing.org



Need for Quality Control / Quantification

- Despite the rapid expansion, quality control procedures for the measurement of 3D printed output lack standardization and consensus among practitioners

Memphis, TN 2016

68th Annual Technical Conference
taga@c.printing.org



One Method



Memphis, TN 2016

68th Annual Technical Conference
taga@c.printing.org



Alternative to High-Resolution Digital Microscopes?

- Measurement of 3D printed materials is especially important
 - Rapid Prototyping
 - Manufacture of Interchangeable Parts
- High-resolution digital microscopes
 - Costly
 - Difficult to Use

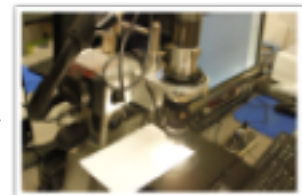

Memphis, TN 2016

68th Annual Technical Conference
taga@c.printing.org



Image Capture from Digital Microscope

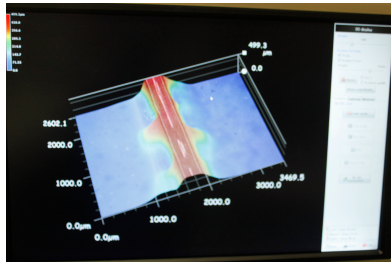

Memphis, TN 2016

68th Annual Technical Conference
taga@c.printing.org



Image Capture from Digital Microscope



Memphis, TN 2016

68th Annual Technical Conference
taga@c.printing.org



A Promising Alternative

- Flexographic Plate Meter specifically designed to measure the height (z-direction) of relief printing plates

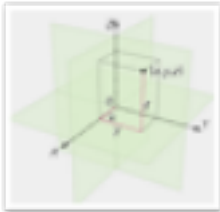

Memphis, TN 2016

68th Annual Technical Conference
taga@c.printing.org



Flexo Plate Measurement: x, y and z Direction

- Although not specifically designed for 3D printed products, if the BetaFlex Pro can successfully measure these materials it could hold promise for quality control applications with 3D printing workflows

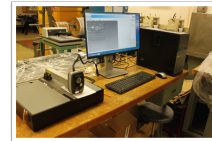

Memphis, TN 2016

68th Annual Technical Conference
taga@c.printing.org



Flexographic Printing

- \$140 Billion Dollar Industry
- Growth Rate: 2.1%/ Annum Real Terms*

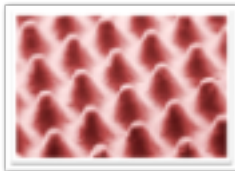

*Source: *Smithers PIRA* 2011

Memphis, TN 2016

68th Annual Technical Conference
taga@c.printing.org



Image Capture from Beta Flex Pro

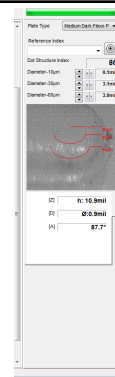
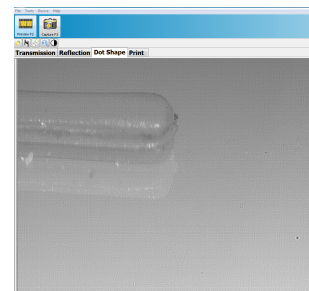

Memphis, TN 2016

68th Annual Technical Conference
taga@c.printing.org



Beta Flex Pro Limitations

- Flexographic Plate Meter specifically designed to measure the height (z-direction) of relief printing plates
 - Limited Depth of Focus
 - Adjustments for Illuminant and Range
 - Corrected for Oblique Angle of Camera
 - Measure up to 0.025" (0.635mm)

Memphis, TN 2016



Optical Controls on Beta Flex Pro

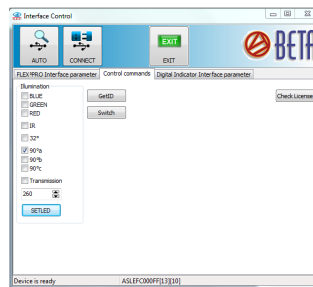

Memphis, TN 2016



Procedure

Design a Sample with a Feature at Specified Heights (SolidWorks Software)

0.024" (0.6 mm) 0.020" (0.5mm) 0.16" (0.4mm)

Output Using Two Methods: Fused-Deposition Modeling (FDM) & Stereolithography (SLA)

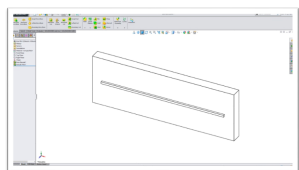

Memphis, TN 2016



FDM and SLA

The Basic Fused-Deposition Modeling Process

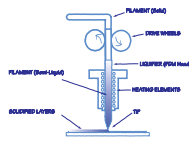

The Basic Stereolithographic Process

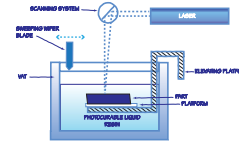

Memphis, TN 2016



Subjective Nature of Evaluations



Memphis, TN 2016



Initial Observations

- FDM Technology results in a poorly rendered line edge, it is nearly impossible to determine the top of the line edge from the side



Memphis, TN 2016



Initial Observations

- SLA Technology results in a more clearly defined line edge, it is easier to visually determine the top of the line edge from the side



Memphis, TN 2016



3D Printing Technologies with Clear Edge Definition

- Implication: the BetaFlex Pro can be useful for this application for certain 3D printing technologies

Memphis, TN 2016



Data Collection

- Three Samples
 - 0.016" (0.4mm)
 - 0.020" (0.5mm)
 - 0.024 (0.6mm)
- Three Trained Operators
- Two Instruments
 - VHX Digital Microscope
 - Beta Flex Pro

Memphis, TN 2016



Descriptives

16	Min	Max	Range	Mean
VHX	11.33	12.4	1.06	11.87
Beta Flex	8.2	10.6	2.4	9.54

20	Min	Max	Range	Mean
VHX	14.16	15.73	1.58	15.01
Beta Flex	13.5	15.9	2.4	14.53

24	Min	Max	Range	Mean
VHX	20.54	21.36	0.82	20.91
Beta Flex	16.6	18.4	1.8	17.3

Memphis, TN 2016

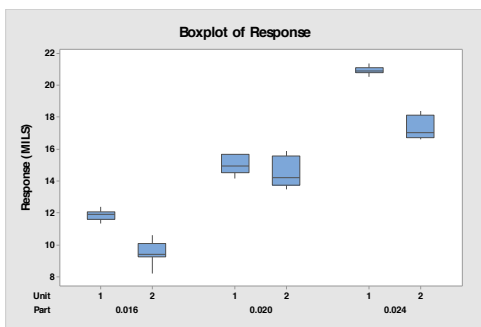

Memphis, TN 2016



Gage R&R

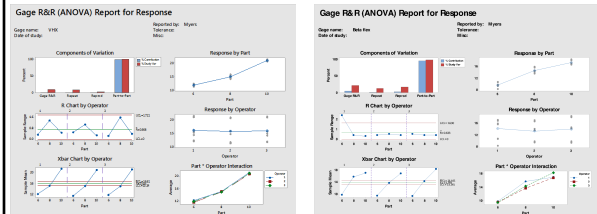

Memphis, TN 2016



Gage R&R

Beta Flex Pro					
Source	DF	SS	MS	F	P
Part	2	278.076	139.038	82.907	0.001
Operator	2	3.567	1.784	1.0636	0.426
Part*Operator	4	6.708	1.677	6.7281	0.002
Repeatability	18	4.487	0.249		
Total	26	292.839			

VHX					
Source	DF	SS	MS	F	P
Part	2	379.029	189.514	3423.26	< 0.001
Operator	2	0.691	0.345	6.24	0.059
Part*Operator	4	0.221	0.055	0.31	0.869
Repeatability	18	3.245	0.180		
Total	26	383.187			

Memphis, TN 2016



Gage R&R

Beta Flex Pro		
Source	VarComp	% Contribution (of VarComp)
Total Gage R&R	0.7370	4.61
Repeatability	0.2493	1.56
Reproducibility	0.4878	3.05
Operator	0.0119	0.07
Operator*Part	0.4759	2.97
Part-to-Part	15.2623	95.39
Total Variation	15.9994	100
Number of Distinct Categories = 6		

VHX		
Source	VarComp	% Contribution (of VarComp)
Total Gage R&R	0.1785	0.84
Repeatability	0.1576	0.74
Reproducibility	0.0209	0.10
Operator	0.0209	0.10
Part-to-Part	21.0397	99.16
Total Variation	21.2181	100
Number of Distinct Categories = 15		

*Automotive Industry Action Group (AIAG) Recommends # of Distinct Categories > 4
And Total Gage R&R Percent Contribution < 10 (in most cases)

Memphis, TN 2016



Other Observations

- A separate mounting system could be devised to simplify sample placement
- 3D printed samples are read in reflection and therefore the illumination is self-contained in the measuring head, a device could be devised to simplify the measurement process using the BetaFlex Pro camera



Memphis, TN 2016



Conclusions

- BetaFlex Pro is limited for measurement of 3D printed samples
 - Fewer Controls
 - Limited to X and Y directions of FDM
 - Faster than VHX Microscope
- Overall, it is unlikely that a 3D printing operation would purchase a BetaFlex Pro for measurement of printed samples, if an organization already had one on hand is useful for measuring line widths and the z-direction of 3D printed samples from technologies that produce clearly defined edges

Memphis, TN 2016



Acknowledgements

Thank you to Larry Goldberg and Beta Screen for their support with the BetaFlex Pro

Sandeep Yanelli and Li Heng RIT School of Media Sciences Graduate Student for her assistance

-Bruce Leigh Myers, Ph.D.
Assistant Professor
-Shu Chang, Ph.D.
Melbert B. Cary Jr. Distinguished Professor

Memphis, TN 2016

